

The Pronto SYSTEM logo features a stylized graphic of three concentric, curved lines in shades of green, resembling a signal or a wave. To the right of this graphic, the word "Pronto" is written in a bold, blue, sans-serif font, and the word "SYSTEM" is written in a bold, black, sans-serif font to its right.

# Pronto SYSTEM

**PRE-IMPREGNATED CLOTH WINDER TECHNOLOGY**

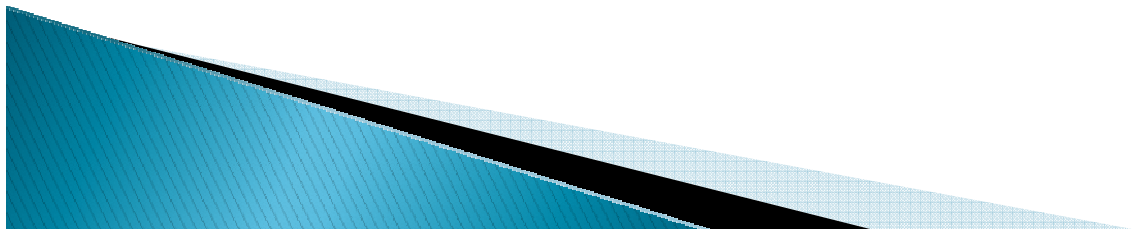

## DESCRIPTION

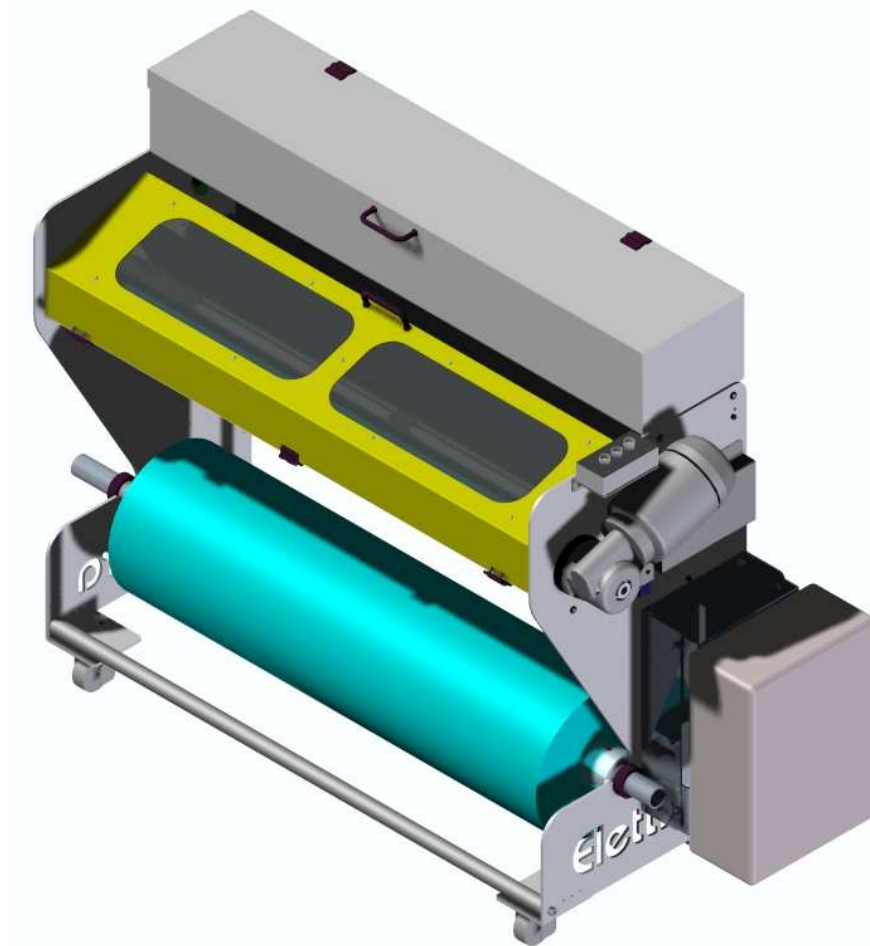

The PRE-IMPREGNATED cloth technology for cleaning the blankets starts from the preparation of the pre-impregnated rolls.

PRONTO SYSTEM is a machine that gives to the End User the possibility to prepare these rollers “in house”, thus saving A LOT OF money ON THE CONSUMABLES

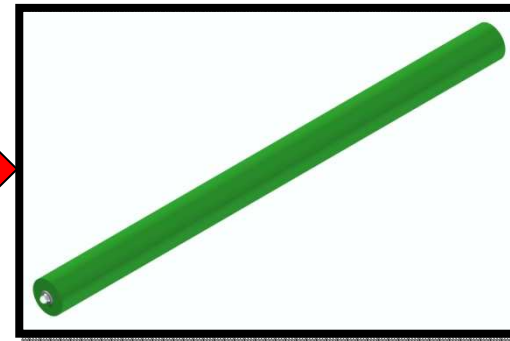
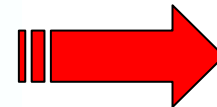

*Elettra Pronto System :  
Wet Mini Rolls Ready to Wash  
Up to 2100 mm Cloth Width*

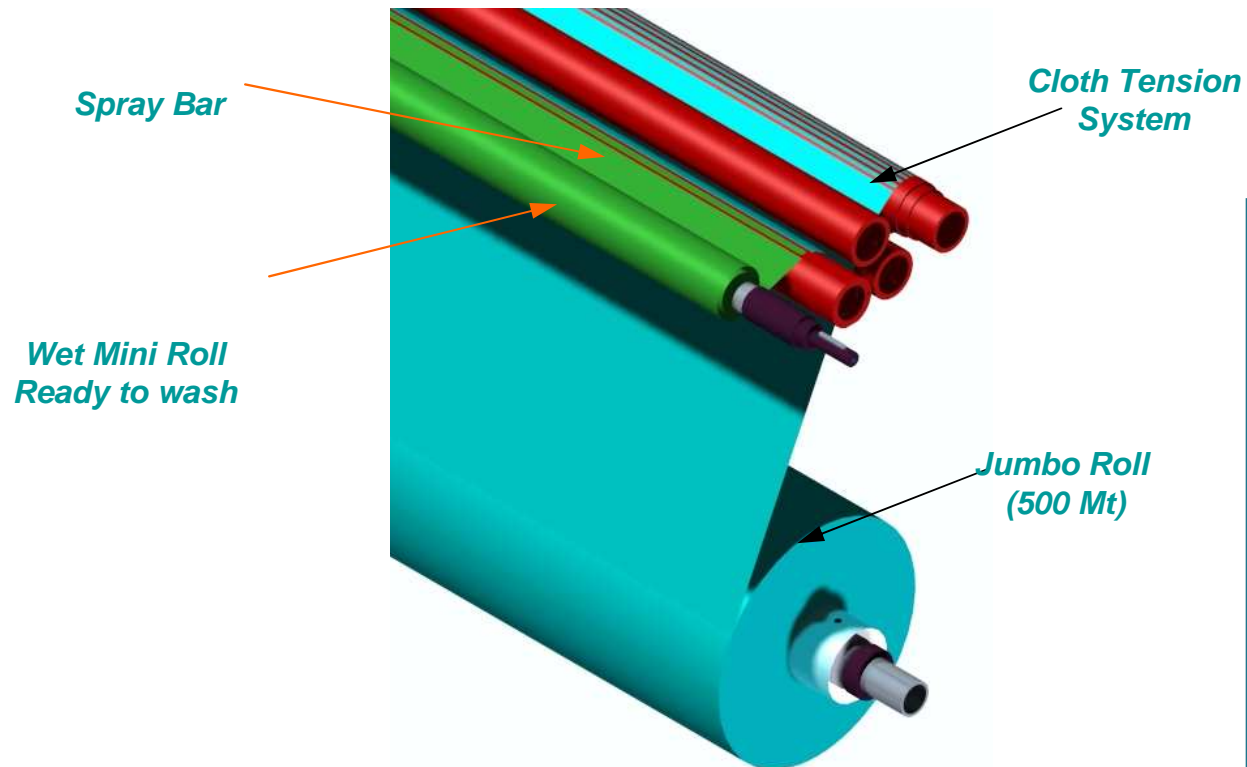

Elettra ProntoSystem allows you to wet the cloth in a very simple and fast operation (see next slide). Starting from the Jumbo roll, you wet the cloth with cleaning agent and wind it onto the spindle.

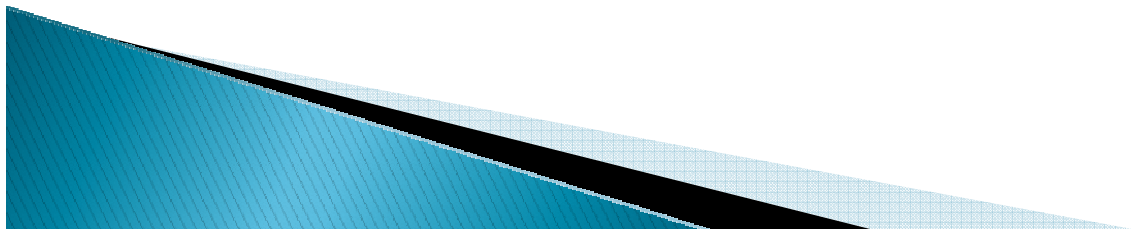

Cloth roll preparation sequence: Make-up in 2 minutes !!!



1. Spindle inserted into the Pronto Rewinder



2. Cloth rewinder on the spindle



3. Start of the Process

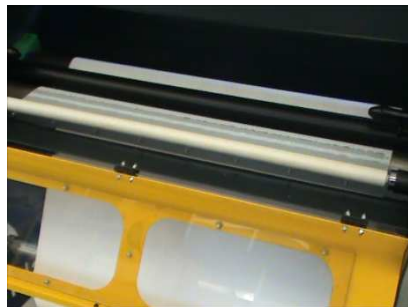

4. Cleaning Agent sprayed into the cloth

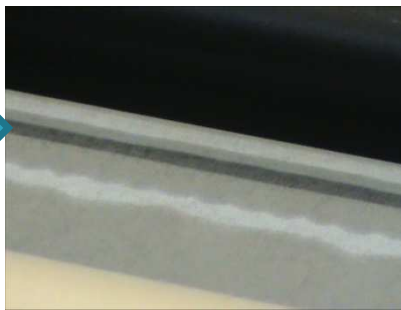

5. Detail of the Spray

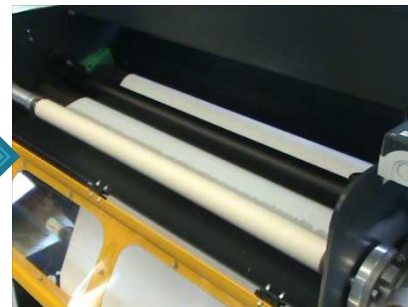

6. End of the Spray Process



7. Cut the Cloth

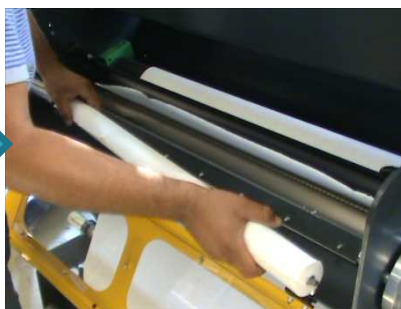

8. The roll is **READY**



9. Pronto System **READY**

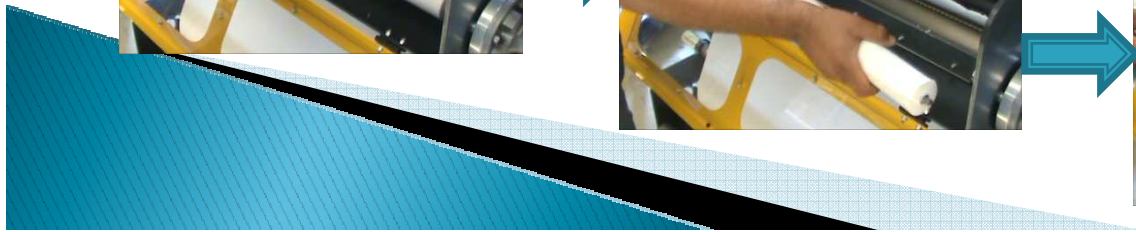



## SOME REASONS TO SELECT PRONTO SYSTEM ...

- EASY-TO-HANDLE MACHINE
- FAST RETURN OF INVESTMENT**
- CONSUMABLES - CLOTH & CLEANING AGENT – **FROM THE MARKET**
- CONSUMABLES - **FROM ELETTRA WITH REALLY ATTRACTIVE CONTRACTS OF SUPPLY** ( BUY THE CONSUMABLES AND YOU WILL HAVE THE PRONTO SYSTEM FREE OF CHARGE )
- EACH SINGLE ROLL WILL BE 40% CHEAPER WHEN COMPARED TO THE COST OF COMPETITORS

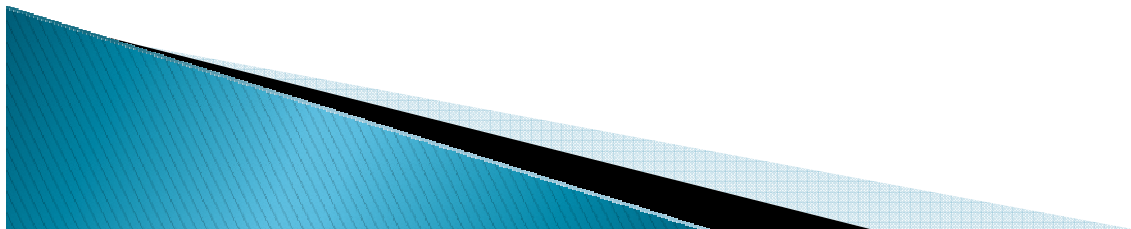



Thank you very much  
for your attention...



ELETTRA S.R.L.  
Via De Gasperi, 2  
23887 Olgiate Molgora – Italy